

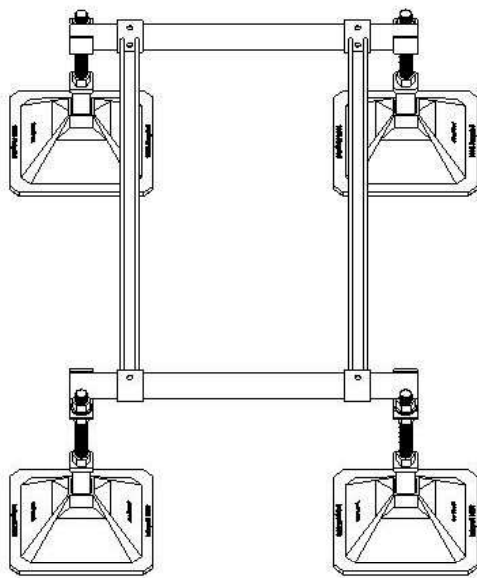

- Easy to adapt & extend to suit most installations and can be extended to any length.
- Channel framework provides strength & convenience for cable management installation
- Cross compatibility with all channel type brackets
- Fast & economical systems for mounting M&E services, Air Conditioning & Refrigeration on flat roofs
- Easy to install for individual products or complete installations
- No penetration of waterproof roof membrane
- Non drill system

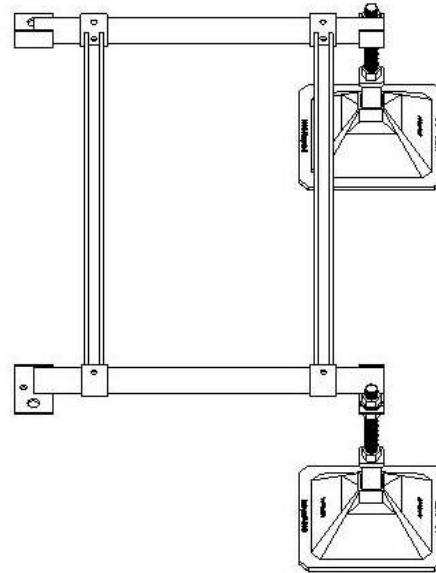

StrutFoot Base System



StrutFoot Plus System

StrutFoot Support System - Technical Information

Part No	Product Description	Complete Leg Assembly	Sliding Arm	Side Rails (mm)	Sliding Arms (mm)	Product Weight (kg)	Max S.W.L (kg)
SF1002	StrutFoot Base	4	2	1000	1300	32	700
SF1004	StrutFoot Plus	2	2	1000	1300	26	350